

# POLIRAN

Drainage system  
**HDPE 6+** Butt Fusion Fittings

PE 100 - PN 6



German Technology

[www.poliran.org](http://www.poliran.org)



Excellent impact resistance  
Even at low temperatures

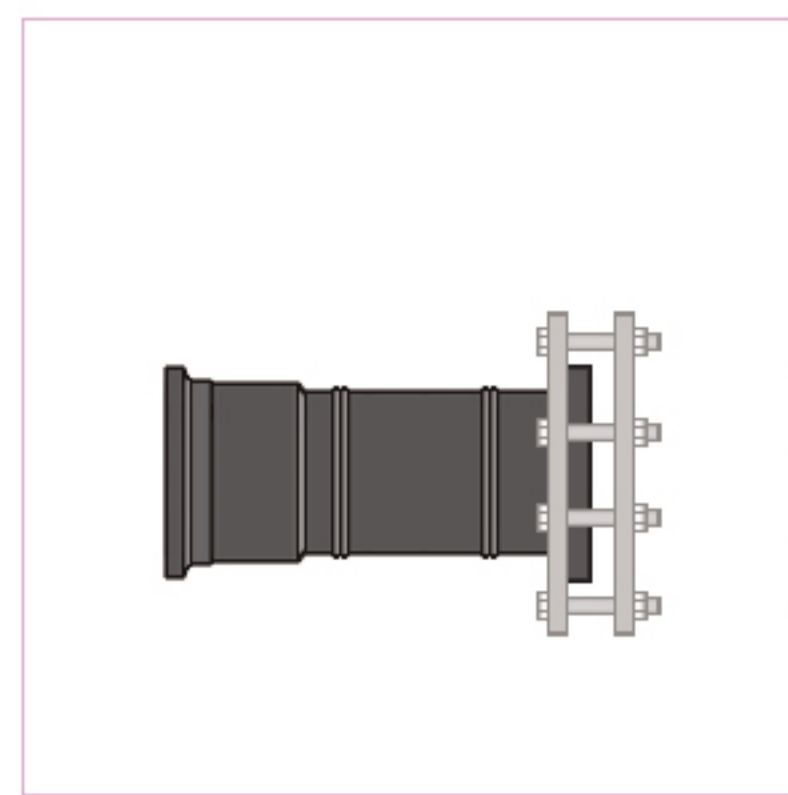

Easy Transition to other systems  
Various solutions available

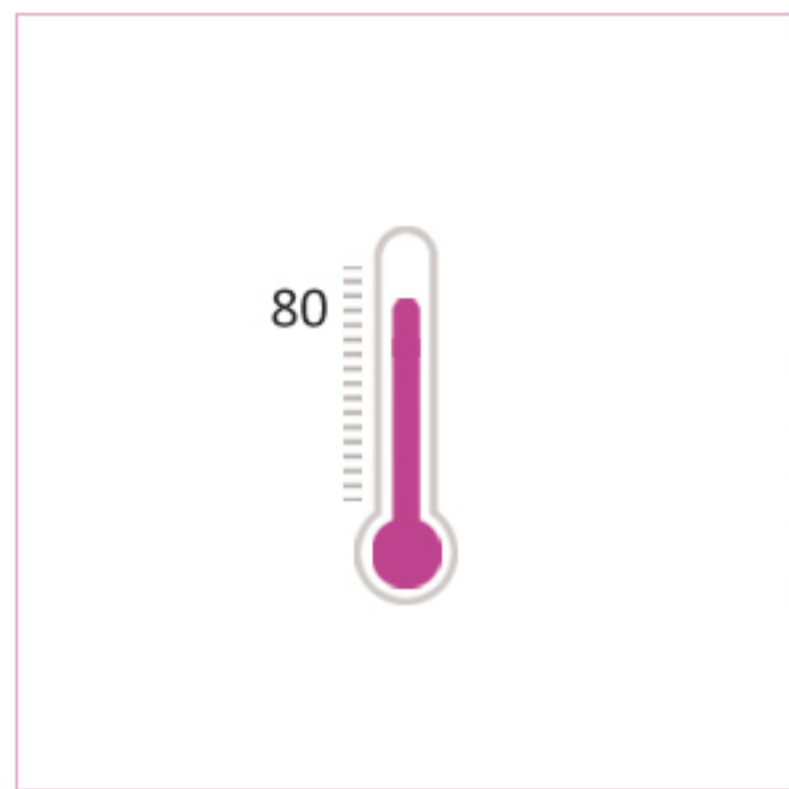

High temperature resistance  
From below zero up to 80°C

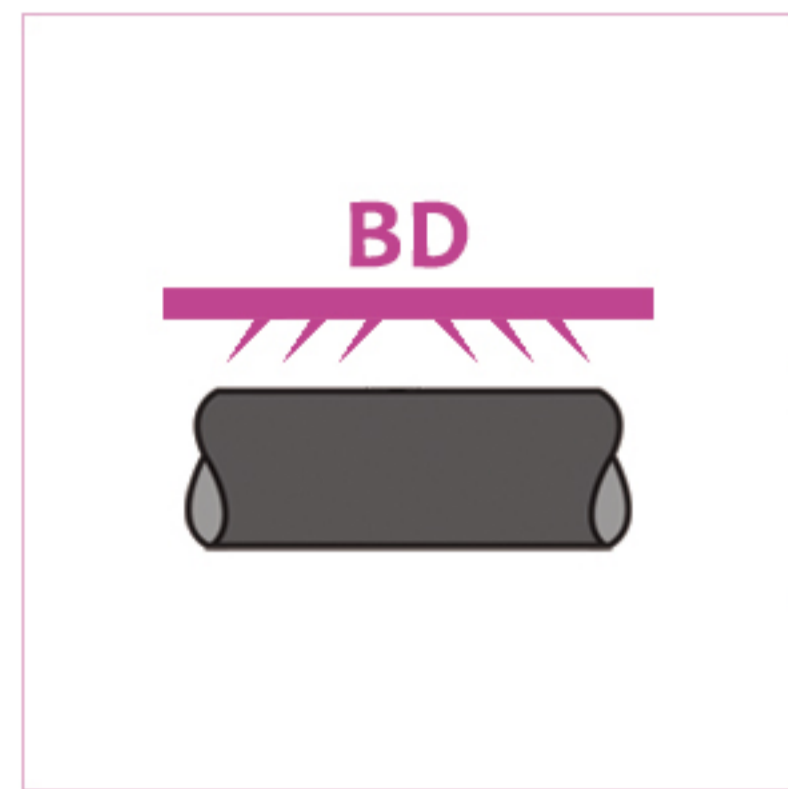

Can be installed underground  
BD application as per EN 1519

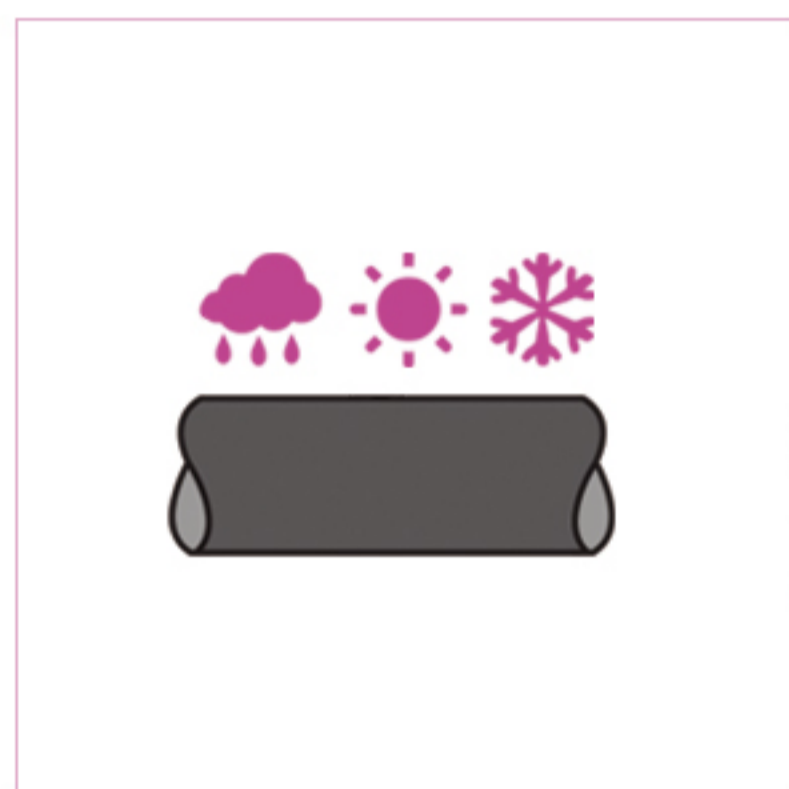

Suitable for outdoor applications  
UV and weather resistant

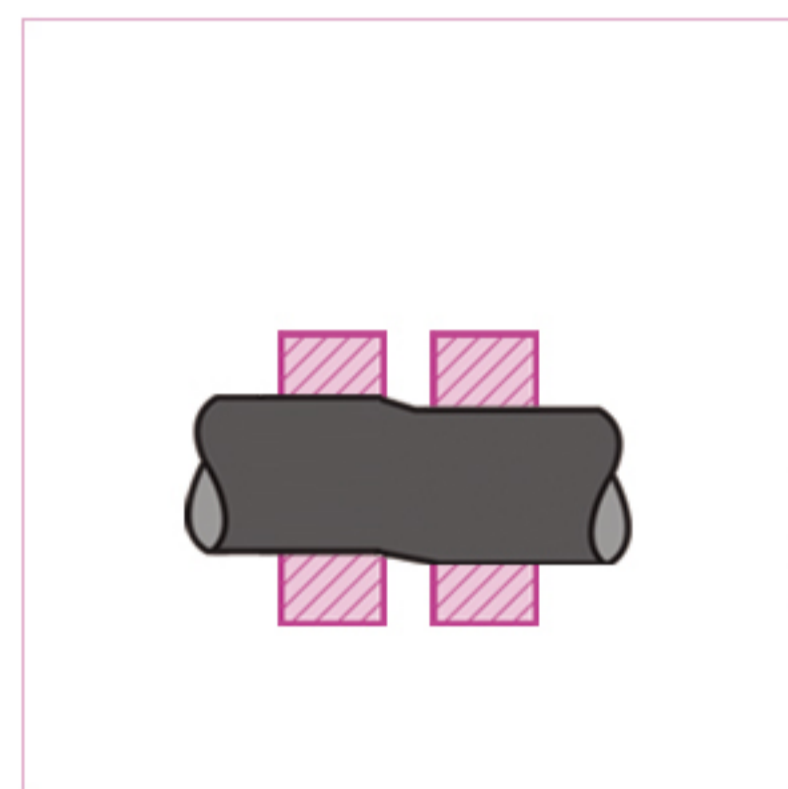

High Flexibility  
Adjusts to ground movements



Excellent chemical resistance  
As per ISO 10358

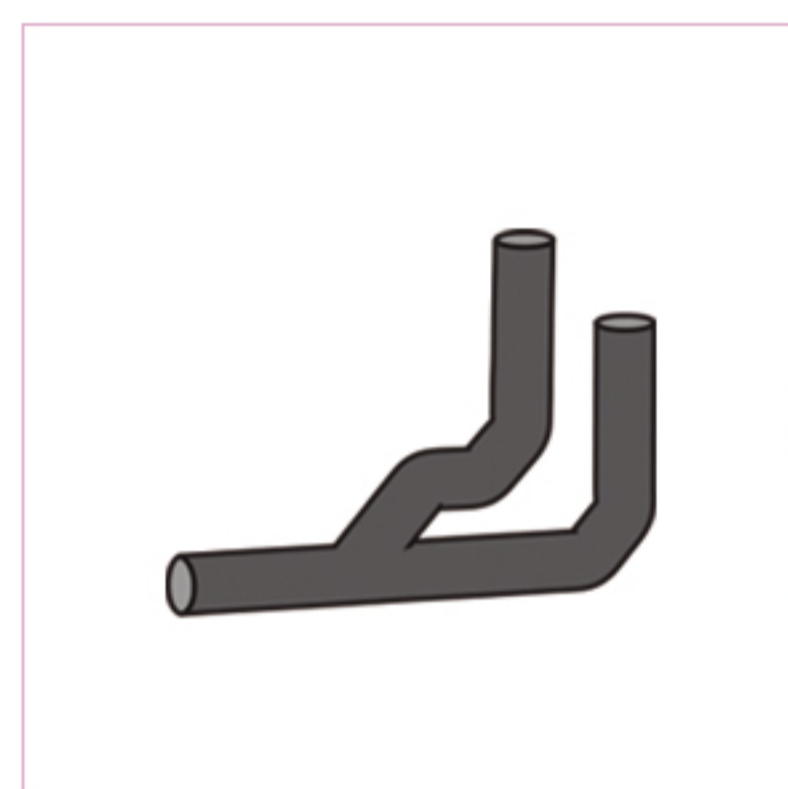

Suitable for prefabrication  
Fast and cost-saving installation



Easy handling & transportation  
Light weight system

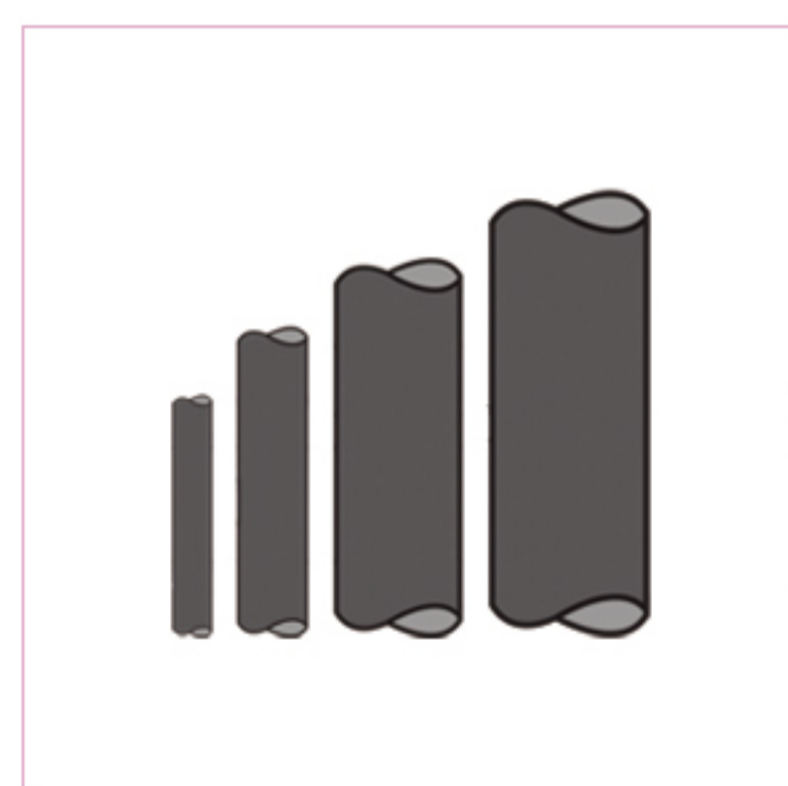

Wide range of pipe and fittings  
DN 50 to DN 250 mm

**Poliran HDPE** is a durable and tough drainage system suitable for all types of drainage systems such as both above and below ground and chemical waste. It is also an excellent choice for commercial applications where a system with high impact and abrasion resistance is required. High flexibility combined with robustness makes it a reliable alternative for conventional materials like cast iron. The system is manufactured from high density polyethylene in compliance with European standard EN 1519. The combination of the excellent material properties of HDPE with homogenous welded joints provides greater installation flexibility with a wide range of jointing options.

Poliran HDPE has an excellent chemical resistance and an extremely smooth internal surface that prevents blockage. To meet all system requirements a complete range of pipes and fittings is available in the diameters of 50 to 250 mm.

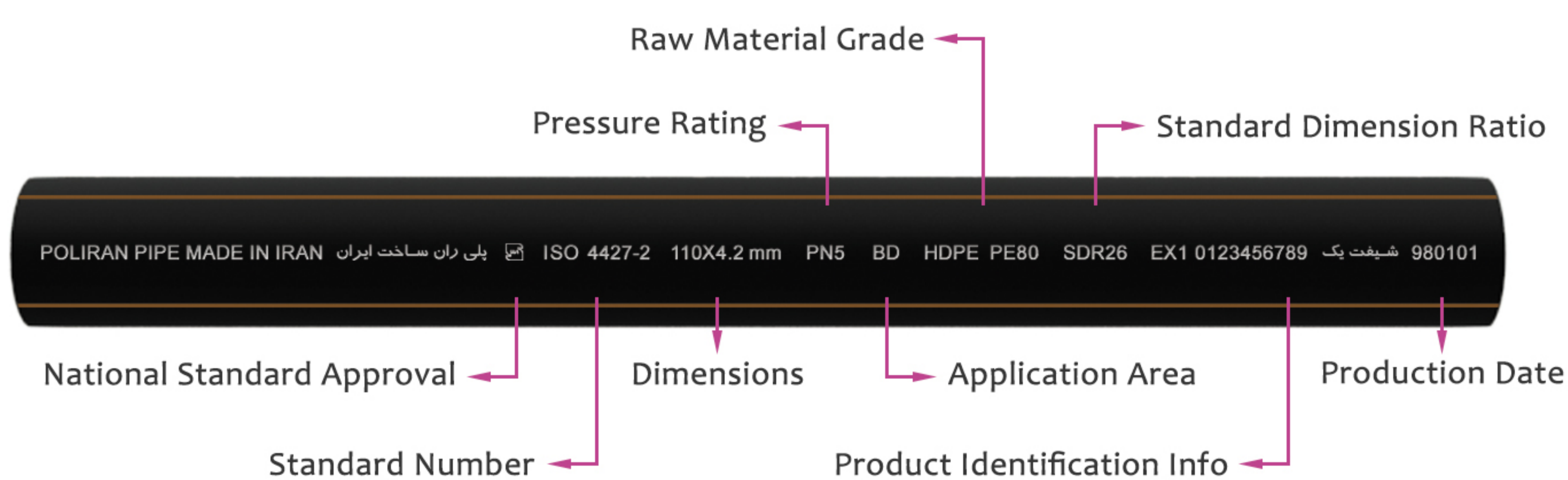

### Standard System Specification

Poliran HDPE is designed to be installed in accordance with EN 12056 for gravity drainage systems inside buildings. Standard system is made of PE80 material and with the nominal pressure of 5 bar (SDR 26).

HDPE pressure pipe system with PE100 material and higher pressure ratings is also available. For more information, please refer to Poliran HDPE Irrigation & Water System catalogue or contact us.

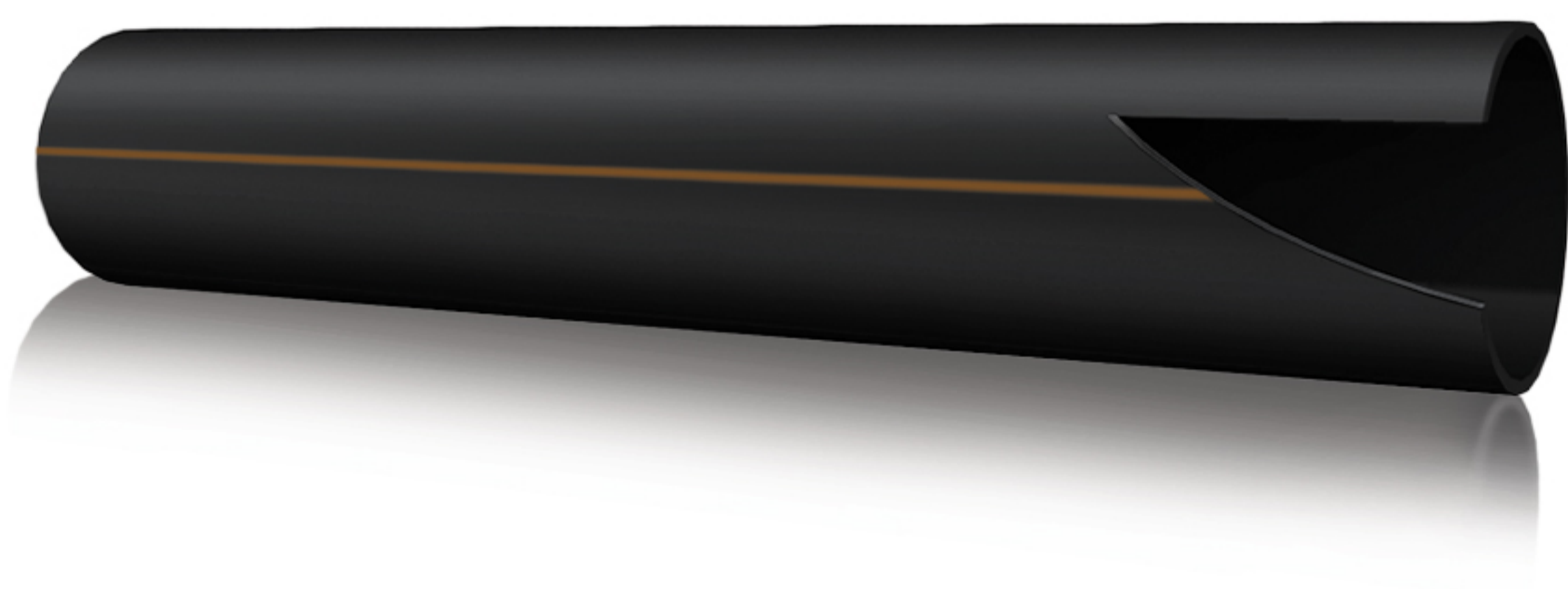

Weight (Kg/m)	Length (m)	Thickness (mm)	OD (mm)
0,314	6	2,0 + 0,3	50
0,494	6	2,5 + 0,4	63
0,675	6	2,9 + 0,4	75
0,980	6	3,5 + 0,5	90
1,430	6	4,2 + 0,6	110
1,840	6	4,8 + 0,6	125
3,040	6	6,2 + 0,8	160
4,690	6	7,7 + 0,9	200
7,300	6	9,6 + 1,1	250

### Thermal movement

Like any other material, HDPE expands or contracts as the temperature changes. Each material has its own unique coefficient of expansion ( $\alpha$ ), for Poliran HDPE  $\alpha=0.19$  mm/m.K

Since thermal expansion in high density polyethylene is relatively higher than other plastic materials, it is important to consider the effects of temperature variations on the system. Poliran recommends using expansion sockets for compensating thermal expansions and contractions.

An expansion socket is a push-fit fitting that can accommodate the expansion and contraction of pipes. The special shape of the lip seal ring allows the pipe to slide within the socket during thermal movements while ensuring the connection remains perfectly watertight.

A fixed pipe clamp must always be located behind the expansion socket to avoid any movement of the socket in the event of expansion or contraction.

An expansion socket can accommodate the thermal changes of pipes of max 6m length.

Push-fit socket (aka short expansion socket) can be used for compensating expansions and contractions of max 3m. it is also used for making easy detachable joints or making a connection to Poliran PP push-fit systems.



**Poliran RC clamps** are especially designed for the soundproof drainage system. A special body section and the use of rubber inlays provide a stable grip while isolating vibrations from the building structure and maintaining acoustic properties.

- Made of electrogalvanized steel. For more corrosion protection zinc flake coating is available upon request
- Specially designed linings made of EPDM rubber
- Excellent strength characteristics with a 3-piece structure
- Suitable for soundproofing other metal or plastic systems
- Simple and fast installation
- Available in 4 different types, from DN50 to DN200 mm
- In accordance with the requirements of DIN 4109 & VDI 4100
- Tested by the renowned Fraunhofer institute of Germany



**Bend - 90°**



50 - 63 - 75  
90 - 110 - 125 - 160

**Bend - 45°**



50 - 63 - 75  
90 - 110 - 125 - 160

**Reducer**



63/50 - 75/50 - 75/63 - 90/63  
90/75 - 110/63 - 110/75 - 110/90  
125/110 - 160/110 - 160/125

**Push-Fit Coupler**



63

**Equal Branch - 45°**



50 - 63 - 75  
90 - 110 - 125 - 160

**Reducing Branch - 45°**



63/50 - 75/63 - 90/63 - 110/63  
110/75 - 110/90 - 125/110 - 160/110

**Equal Branch - 90°**



50 - 63 - 75  
90 - 110 - 125 - 160

**Reducing Branch - 90°**



63/50 - 110/63 - 160/110

**Double Branch - 45°**



63 - 110

**Y-piece - 60°**



63

**Access Pipe - 45°**



63

**Access Pipe - 90°**



63 - 110

**P-Trap**



50 - 63 - 75 - 90 - 110

**Protective Cap**



63 - 75 - 90 - 110

**End Cap (Butt-Weld)**



50 - 63 - 75  
90 - 110 - 125 - 160

**Clean-Out**



50 - 63 - 75  
110 - 125 - 160

**Fabricated Fittings**



Upon Request

**Stand Pipe Clamp**



50 - 63 - 75 - 90  
110 - 125 - 160 - 200 - 250

**Weldable Clamp**



40 - 50 - 63 - 75  
90 - 110 - 125 - 160

**Adjustable Clamp**



50 - 63 - 75 - 90  
110 - 125 - 160 - 200 - 250

## Joining Methods

Poliran HDPE system offers different joining methods suitable for various situations. There are two type of joining methods; mechanical and welded joints.

Butt-Welding is the simplest welded joint that is made without additional glue or rubber rings and are actually the strongest point of the system. This is a permanent joint that cannot be disconnected and will remain closed for its lifetime. This joining method is very suitable for prefabrication and producing special fittings.

Mechanical joining methods available are push-fit socket, expansion socket and flanges. These are joining methods that can be disconnected after assembly and are ideal for pipe sections which need to be cleaned and inspected or where making a butt-weld joint is not easily possible.

## Prefabrication

One of the major advantages of HDPE system is the capability of prefabricating the repetitive parts of system which are then assembled on the building site by means of a mechanical joint. Prefabrication saves time during installation and ensures more reliable butt-welded joints are made under the controlled conditions of the prefabrication workshop. The advantages of prefabrication are especially tangible in buildings with numerous identical pipe sections, such as hospitals and residential buildings.

Light weight of HDPE allows easy handling and low-cost transportation of prefabricated parts while its high flexibility and impact-resistance minimizes the risk of breakage and deformation.

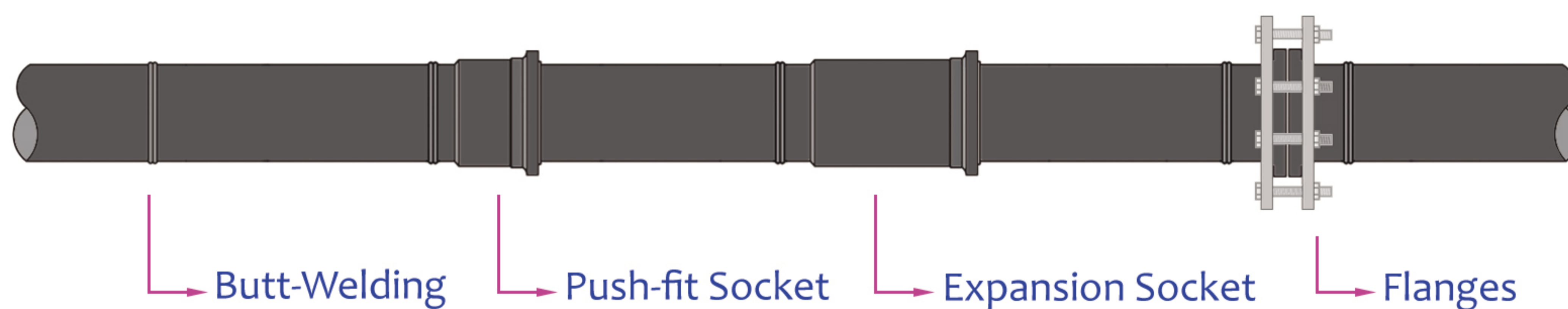

EN 1519 | ISO 4427-1 | EN 12201-1 | EN 681 | INSO 14427 | DIN 16963

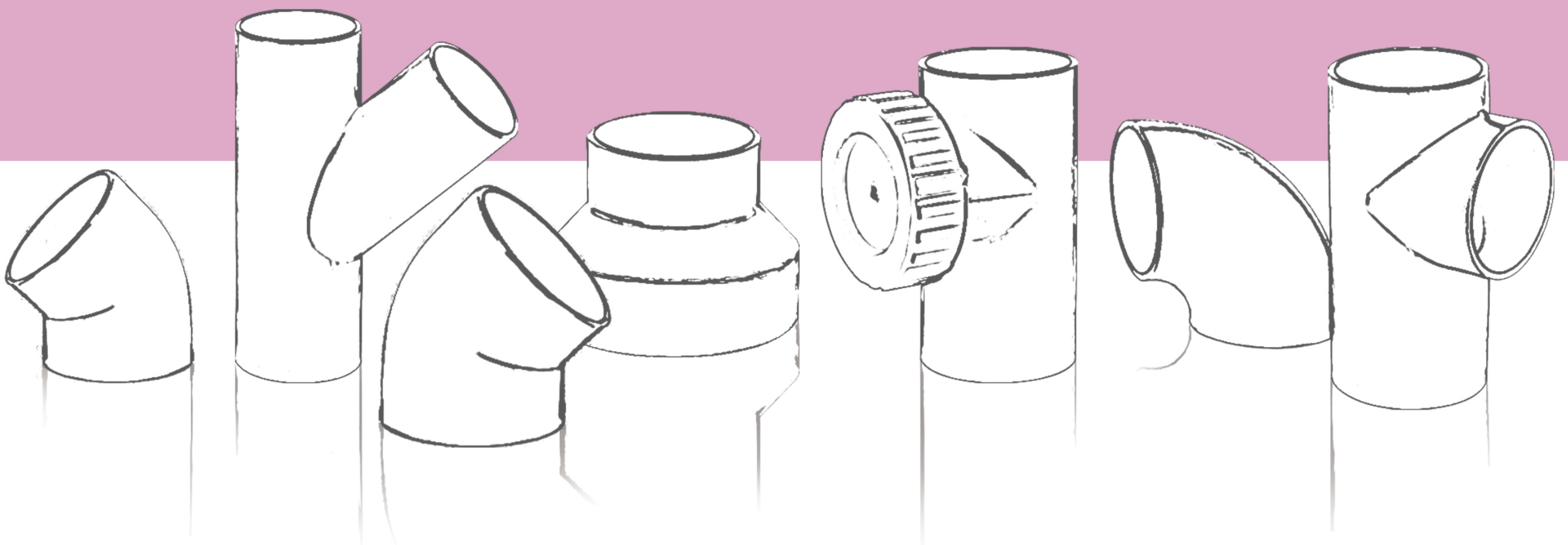

## About Us

Founded in 1971, Poliran is the leading manufacturer of plastic pipe systems in Iran, providing state-of-the-art solutions for pipes and fittings used in water conveyance, irrigation and building water supply and drainage systems.

Deep attention to quality requirements and continuous improvement of products, as well as using best raw materials and up to date technologies have kept Poliran at the forefront of manufacturing plastic pipe systems. To achieve our quality objectives, we have adopted ISO 9001 Quality Management System and we aim to be the quality leader in our sector.

Our technical department provides complete support during design and installation thanks to a team of experienced engineers and experts, capable of dealing with the most complex system requirements.



## Some of our projects:



Follow us on  
Social Media

POLIRAN Building, No. 17,  
Zagros St., Arjantin Sq.,  
Tehran, Iran  
Postal Code : 1516643311  
Tel : +98 21 88648843  
export.dep@poliran.org  
WhatsApp : +98 912 9465921